

**HARBINGER™**

# HA60 Owner's Manual

## 4-Channel 60-Watt PA System



# Welcome

Congratulations on your purchase of Harbinger's HA60 4-Channel 60-Watt PA System. Built with rugged, ozite-covered wood enclosures, the HA60 is the ideal choice for musicians looking for a PA that delivers great sound, night after night.

This manual will help you setup your new system. By following our guidelines and suggestions, your new Harbinger will provide many years of great sound and reliable service.

Your new PA includes:

- 4 mono mic/line input channels w/ XLR and 1/4" jacks
- Built-in 60 watt power amplifier (max.output)
- Built-in Digital Delay
- 2-Band EQ at mono channels
- Record out
- Aux in with level control

## FCC Statements

1. Caution: Changes or modifications to this unit not expressly approved by the party responsible for compliance could void the user's authority to operate the equipment.
2. Note: This equipment has been tested and found to comply with the limits for a Class B digital device, pursuant to Part 15 of the FCC Rules. These limits are designed to provide reasonable protection against harmful interference in a residential installation. This equipment generates, uses, and can radiate radio frequency energy and, if not installed and used in accordance with the instructions, may cause harmful interference to radio communications. However, there is no guarantee that interference will not occur in a particular installation. If this equipment does cause harmful interference to radio or television reception, which can be determined by turning the equipment off and on, the user is encouraged to try to correct the interference by one or more of the following measures:
  - Reorient or relocate the receiving antenna.
  - Increase the separation between the equipment and receiver.
  - Connect the equipment into an outlet on a circuit different from that to which the receiver is connected.
  - Consult the dealer or an experienced radio/TV technician for help.

# Important Safety Instructions

**DANGER**

Exposure to extremely high noise levels may cause permanent hearing loss. Individuals vary considerably to noise-induced hearing loss but most will lose some hearing if exposed to intense noise for a sufficient period of time.

The U.S. Government's Occupational Safety and Health Administration (OSHA) has specified the following permissible noise level exposures:

DURATION PER DAY (HOURS)	8	6	4	3	2	1
SOUND LEVEL (dB)	90	93	95	97	100	103

According to OSHA, any exposure in the above permissible limits could result in some hearing loss. Ear plugs or protectors in the ear canal or over the ears must be worn when operating this amplification system in order to prevent a permanent hearing loss. If exposure in excess of the limits as put forth above, to insure against potentially harmful exposure to high sound pressure levels, it is recommended that all persons exposed to equipment capable of inducing high sound pressure levels, such as this amplification system, be protected by hearing protectors while this unit is in operation.

**CAUTION**  
RISK OF ELECTRIC SHOCK  
DO NOT OPEN

**CAUTION:** TO REDUCE THE RISK OF ELECTRIC SHOCK, DO NOT REMOVE CHASSIS. NO USER-SERVICEABLE PARTS INSIDE. REFER SERVICING TO QUALIFIED SERVICE PERSONNEL.

*AVIS: RISQUE DE CHOC ELECTRIQUE-NE PAS OUVRIR.*

THIS SYMBOL IS INTENDED TO ALERT THE USER TO THE PRESENCE OF NON-INSULATED "DANGEROUS VOLTAGE" WITHIN THE PRODUCT'S ENCLOSURE THAT MAY BE OF SUFFICIENT MAGNITUDE TO CONSTITUTE A RISK OF ELECTRIC SHOCK TO PERSONS

THIS SYMBOL IS INTENDED TO ALERT THE USER TO THE PRESENCE OF IMPORTANT OPERATING AND MAINTENANCE (SERVICING) INSTRUCTIONS IN THE LITERATURE ACCOMPANYING THE UNIT.

APPARATUS SHALL NOT BE EXPOSED TO DRIPPING OR SPLASHING AND THAT NO OBJECTS FILLED WITH LIQUIDS, SUCH AS VASES, SHALL BE PLACED ON THE APPARATUS.

**IMPORTANT SAFETY INSTRUCTIONS**

1. Read all safety and operating instructions before using this product.
2. All safety and operating instructions should be kept for future reference.
3. Read and understand all warnings listed on the operating instructions.
4. Follow all operating instructions to operate this product.
5. This product should not be used near water, i.e. a bathtub, sink, swimming pool, wet basement, etc.
6. Use only a dry cloth to clean this product.
7. Do not block any ventilation openings. The product should not be placed flat against a wall or placed in a built-in enclosure that will impede the flow of cooling air.
8. Do not install this product near any heat sources, such as radiators, heat registers, stoves or any other apparatus (including heat producing amplifiers) that produces heat.
9. Do not defeat the safety purpose of the polarized or grounding-type plug. A polarized plug has two blades with one wider than the other. A grounding-type plug has two blades and a third grounding prong. The wide blade or the third prong are provided for your safety. If the provided plug does not fit into your outlet, consult an electrician for replacement of the obsolete outlet.
10. Protect the power cord being walked on or pinched, particularly at plugs, convenience receptacles and the point where they exit from the apparatus. Do not break the ground pin of the power supply cord.
11. Only use attachments specified by the manufacturer.
12. Use only with the cart, stand, tripod, bracket, or table specified by the manufacturer or sold with the apparatus. When a cart is used, use caution when moving cart/apparatus combination to avoid injury from tip-over.
13. Unplug this apparatus during lightning storms or when unused for long periods of time.
14. Care should be taken so that objects do not fall and liquids are not spilled into the unit through the ventilation ports or any other openings.
15. Refer all servicing to a qualified service professional. Servicing is required when the apparatus does not operate normally or has been damaged in any way, including damage to the power cord or plug, damage due to liquids spilled or objects dropped inside the unit, dropping the unit, or anything else that interrupts normal use of the unit.
16. **WARNING:** To reduce the risk of fire or electric shock, do not expose this apparatus to rain or moisture
17. When a mains plug is used as the disconnect device, the disconnect device shall remain readily operable.

# Input Channels

- 1 LOW EQ**  
This shelving control gives 15dB of boost or cut at 80Hz. Add warmth to vocals or extra punch to guitars, drums and synths by turning to the right. Turn to the left to reduce stage rumble, hum or to improve a muddy sound.
- 2 HIGH EQ**  
This shelving control gives 15dB of boost or cut at 12KHz. Turn to the right to boost high frequencies, adding crispness to percussion from drum machines, cymbals and synths. Turn to the left to cut these frequencies, reducing sibilance or hiss.
- 3 VOLUME**  
This level control determines the proportion of the channel signal in the mix, and provides a clear visual indication of channel level.
- 4 FX**  
This knob sets the amount of signal level that will be sent to the built-in digital delay effect.
- 5 MIC & LINE INPUT**  
This MIC input accepts male XLR while the LINE input accepts a 1/4" type phone plug. Please use a low impedance microphone and a properly wired cable for best results. You can only use one of the two connectors at the same time.

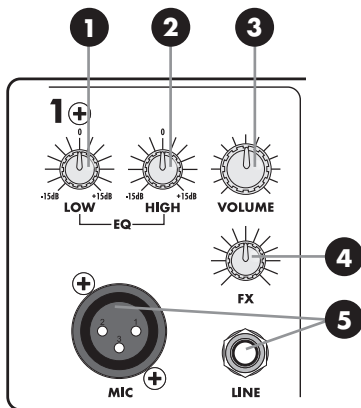

# Master Section

- 6** The signal from the input channels, processed by the built-in digital delay will feed to the master output. There are three knobs here to control the effect of digital delay.
  - FX MASTER:** This knob adjusts the mix level of the effect sound.
  - TIME:** This knob adjusts the internal time of the delays; turn to the right to increase the interval time between two delays.
  - REPEAT:** To increase the rate of the delays, turn this knob to the right. You will hear the signal repeat at a faster rate.
- 7 POWER INDICATOR**  
When the power switch at the rear panel is turned on, this indicator will illuminate so the user may be aware of it.
- 8 AUX IN CONTROL**  
This knob adjusts the level of signal from the AUX Inputs to the Master Volume.
- 9 MASTER VOLUME**  
This adjusts the final level of the Output Volume. Turn Master Volume down before turning unit on or off.
- 10 AUX IN & REC OUT**  
The AUX IN Phono Jacks allow MP3/CD players to be connected to the amplifier. The RECORD OUTPUT RCA Phono Jacks, provide signal output to audio equipment. The nominal output level and impedance are -10dBV/600ohms.

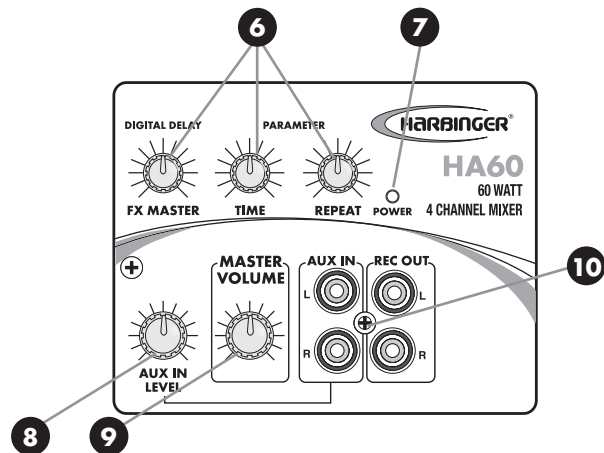

# Rear Panel

- 1 AC POWER**  
Power cable.
- 2 POWER SWITCH**  
This switches the powered mixer on and off. While on, the power on blue LED indicator will light up on the master section of front panel.
- 3 SPEAKER OUTPUT JACKS**  
Connect both speakers to these Jacks. The minimum impedance load is 4 Ω. Do not connect more than two 8 Ω speakers, or damage may occur.

- 4 MAIN INSERT**  
This unbalanced insert point is a break between the main out and built-in amplifier to allow the main output to be sent to an external signal processor. The insert is a 1/4" TRS phone jack which is normally bypassed. When a jack is inserted, the signal path is broken.  
  
The main output signal appears on the TIP of the plug and the external signal is returned on the RING. An unbalanced 1/4" insert cable may be required to connect to equipment with separate send and return jacks as shown below:

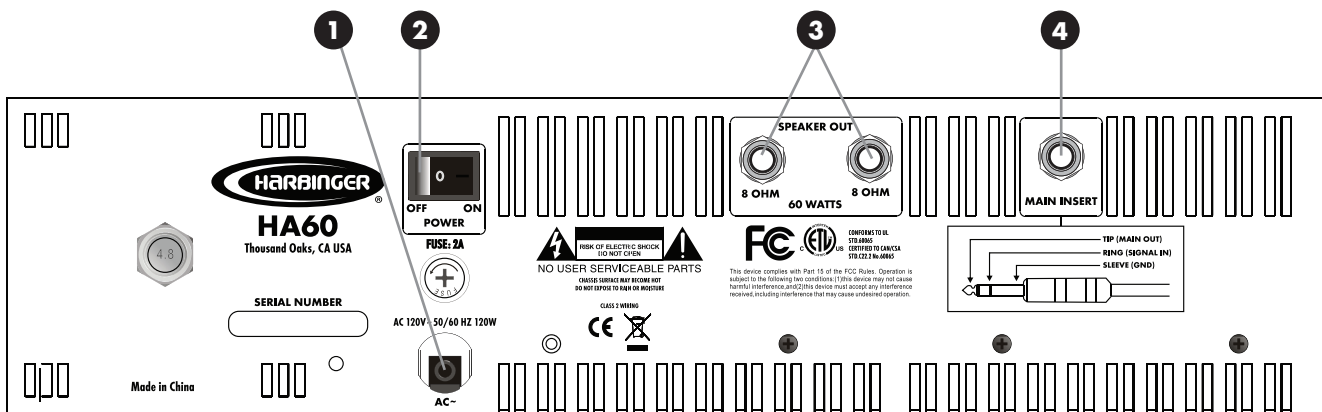
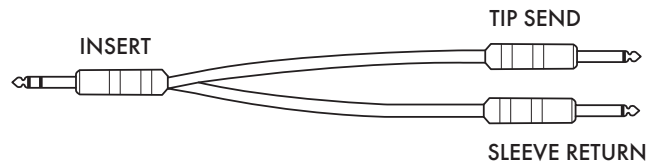

# General Application (Input)

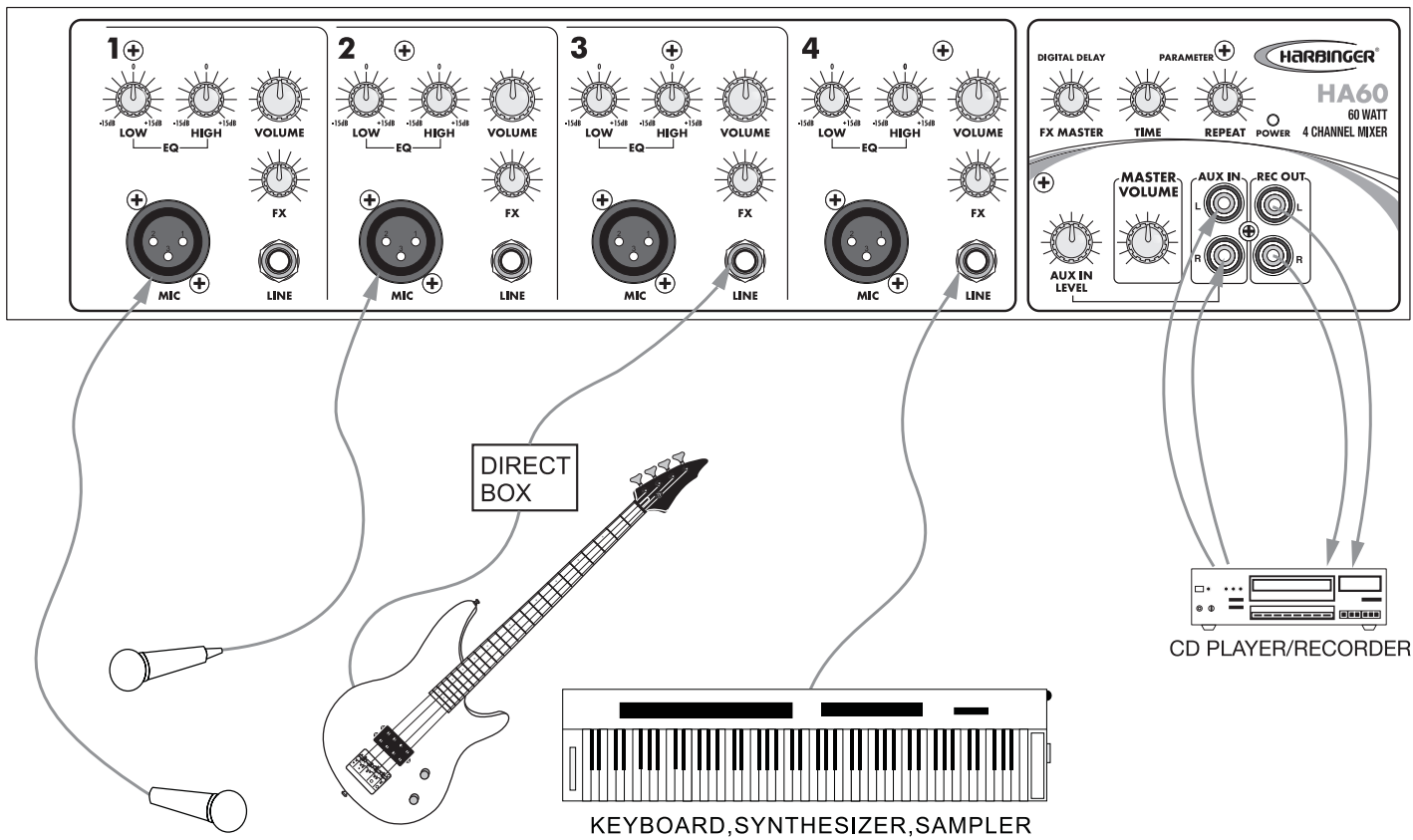

# General Application (Output)

## PA SPEAKERS

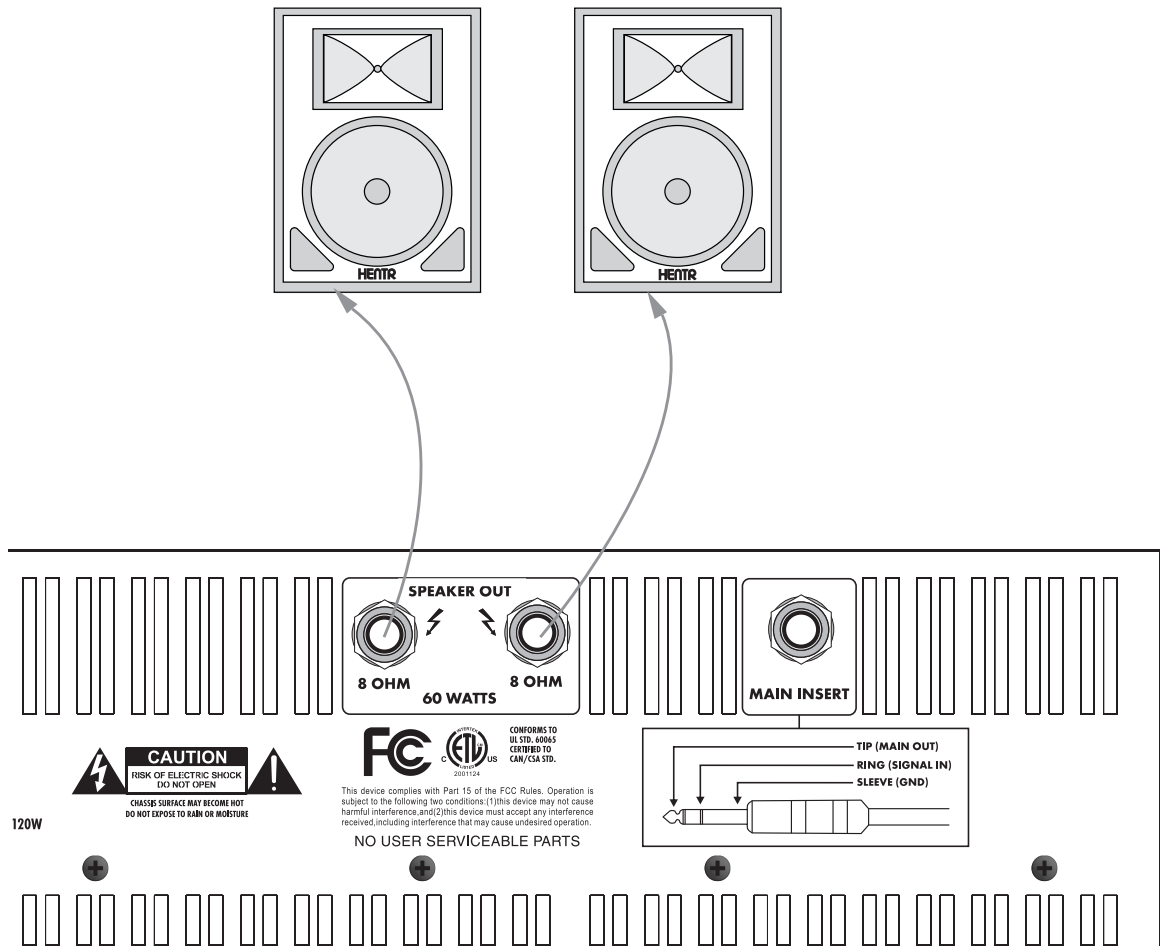

**CAUTION:** Minimum 4 Ω load. Use a maximum of two 8 Ω speakers.

# Power Amp Specifications

## POWER AMP

Max Output Power (watts): 8  $\Omega$ -45  
 Minimum 4  $\Omega$  load 4  $\Omega$ -60

## INPUTS

Balanced mono: 4 Mic/line channels  
 2 Aux Inputs

## OUTPUTS

Record Out RCA Pair

## CHANNEL STRIPS (4)

Volume Controls: Rotary

## MASTER SECTION

Rotary Fader: Master

## BUILT-IN DIGITAL EFFECT

Digital Delay (2-150ms)

## NOISE

Bandwidth-20Hz to 20kHz (line inputs to master output)

Master output (all faders down): -86dBu

Power amp output, all faders down: -55dBu

## THD

Power output, 20Hz to 20kHz 20Hz to 20kHz

@60 watts: 4  $\Omega$  <1%

## CROSSTALK (1KHZ@ ODBU)

20Hz to 20kHz bandwidth, channel in to master output

Channel fader down -63dB

## FREQUENCY RESPONSE (MIC INPUT TO OUTPUT)

20Hz to 20kHz line level o/p @+4dBu into 600  $\Omega$  +1/-3dB

20Hz to 20kHz power amp o/p 1 watt into 8  $\Omega$  +1/-3dB

## SENSITIVITY @ MIXER OUTPUT +4DBU

Mic/Line: -50dBu

Tape in: -6dBu

## CHANNEL EQUALIZATION

2 band +/-15dB

Low EQ: 80Hz

Hi EQ: 12kHz

## MICROPHONE PREAMP E.I.N.

(150  $\Omega$  terminated, max gain)

-122dBm

## POWER REQUIREMENTS

100-120/220-240 VAC, 50-60Hz

## DIMENSIONS (WxHxD)

18.31"x 6.10"x 8.27"

## WEIGHT

16.31 lbs.



# Speaker Specifications

**RMS POWER HANDLING**

---

50W / 8  $\Omega$ **PEAK POWER HANDLING**

---

80W / 8  $\Omega$ **IMPEDANCE LOAD**

---

8  $\Omega$ **HORN CONSTRUCTION**

---

Piezo (piezoelectric)

**WOOFER CONSTRUCTION:**

---

10" cone diaphragm

**MAGNET WEIGHT**

---

20 oz

**FREQUENCY RESPONSE**

---

40HZ-20kHz

SPL" 95 db +/-2 db

**MAX SPL**

---

114 db

**DIMENSIONS OF SPEAKER BOX**

---

H18.7"xW12.7"/9" x D11.2"

**NET WEIGHT**

---

16.6 lb (per speaker box)

NOTE: The max power (peak) of each speaker box is 80W in order to satisfy the powered mixer's output (max in 80W/8  $\Omega$ ) and to avoid speaker burnout during peak output.

# Block Diagram

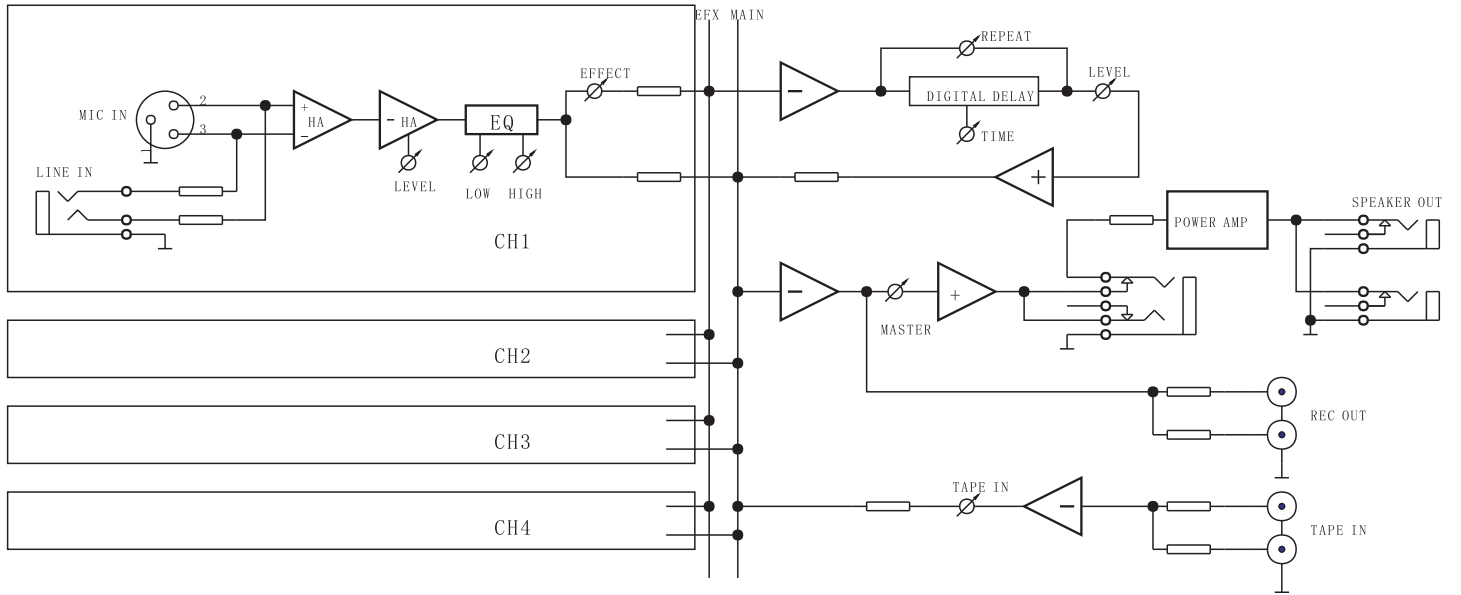

# Warranty

So we may serve you better, please register on-line at [www.HarbingerProAudio.com](http://www.HarbingerProAudio.com)

**2 Harbinger Limited Warranty** Harbinger provides to the original purchaser a two (2) year limited warranty on materials and workmanship on all Harbinger cabinets and loudspeaker components from the date of purchase.

If your covered product is defective, ship the defective component together with proof of purchase, freight prepaid and insured, to an Authorized Harbinger repair center or directly to Harbinger Support Headquarters. If you are uncertain which component is defective, or to obtain instructions for removing a component, please contact Harbinger Support Headquarters for assistance at [support@HarbingerProAudio.com](mailto:support@HarbingerProAudio.com), or visit [www.HarbingerProAudio.com](http://www.HarbingerProAudio.com).

A Return Authorization Number must be obtained from our Customer Service Department prior to shipping the product. To locate a repair center near you and to obtain a Return Authorization Number, contact [support@HarbingerProAudio.com](mailto:support@HarbingerProAudio.com) or visit [www.HarbingerProAudio.com](http://www.HarbingerProAudio.com).

This warranty does not cover service or parts to repair damage caused by neglect, abuse, normal wear and tear and cosmetic appearance to the cabinetry not directly attributed to defects in materials or workmanship. Also excluded from coverage are damages caused directly or indirectly due to any service, repair(s), or modifications of the cabinet, which have not been authorized or approved by Harbinger. This two (2) year warranty does not cover service or parts to repair damage caused by accident, disaster, misuse, abuse, burnt voice-coils, over-powering, negligence, inadequate packing or inadequate shipping procedures. The sole and exclusive remedy of the foregoing limited warranty shall be limited to the repair or replacement of any defective or non-conforming component. All warranties including, but not limited to, the express warranty and the implied warranties of merchantability and fitness for a particular purpose are limited to the two (2) year warranty period. Some states do not allow limitations on how long an implied warranty lasts, so the above limitation may not apply to you. There are no express warranties beyond those stated here. In the event that applicable law does not allow the limitation of the duration of the implied warranties to the warranty period, then the duration of the implied warranties shall be limited to as long as is provided by applicable law. No warranties apply after that period.

Retailer and manufacturer shall not be liable for damages based upon inconvenience, loss of use of product, loss of time, interrupted operation or commercial loss or any other incidental or consequential damages including but not limited to lost profits, downtime, goodwill, damage to or replacement of equipment and property, and any costs of recovering, reprogramming, or

reproducing any program or data stored in equipment that is used with Harbinger products. This guarantee gives you specific legal rights. You may have other legal rights, which vary from state to state.

California Prop 65 Warning: This product may contain a chemical(s) known to the state of California to cause cancer or birth defects or other reproductive harm.

Harbinger, P.O. Box 5111, Thousand Oaks, CA 91359-5111

All trademarks and registered trademarks mentioned herein are recognized as the property of their respective holders.

Made in China  
0907-9061



# SOUNDENGINEERING

For even more  
great-sounding  
speaker options, check out  
Harbinger's entire line at  
[harbingerproaudio.com](http://harbingerproaudio.com)



[HarbingerProAudio.com](http://HarbingerProAudio.com)

©2009 Harbinger